

Infra-Red Science and Technology Integration Group

Contents

- 1 From the SIG Leadership
- 2 IRSTIG January 2022 AAS Splinter Session
- 3 IRSTIG Workshop: Mar 30 – Apr 1, 2022
- 4 Astro2020 Report Paints the IR Landscape for the Next Decade

Science Highlight

- 6 Early Science Results from the CO Mapping Array Pathfinder

Technology Highlight

- 9 Highly multiplexed readout for TES bolometer arrays
- 13 SOFIA Support Letter
- 17 Upcoming Events
- 19 IRSTIG Leadership Council

Follow us on Twitter!



From the IR STIG Leadership Council

It's an exciting time in IR astrophysics. JWST has successfully launched and deployed and is mere days away from turning on its instruments. The Decadal Survey was released a few months ago and lays out some inspirational goals for astrophysics. Of particular interest to our community, the recommendation of a Probe-class line explicitly calling out missions like a far-IR surveyor will spur renewed, vigorous interest in technology development and science in an underserved region of the EM spectrum. However, challenges remain. Recommendations relating to SOFIA and the ballooning program must be addressed, and the challenges of maintaining and improving capability at mid-IR wavelengths and ground-based facilities at longer wavelengths has never been stronger. In this newsletter, you will find some initial responses to these developments from the community. To help coordinate our community and take advantage of the dynamic landscape, the IR STIG is organizing a community-wide workshop to discuss the present and future of our field. Details about this in person meeting scheduled for March 30 – April 1 in Boulder CO can be found within. We hope you consider joining the discussion.

You might also have noticed that our name has changed recently – We are now officially the Infrared Science and Technology Integration Group (IRSTIG). As we move forward post-decadal survey, we think that this name change better reflects our commitment to bring together the entire IR community, both observations and technology. The STIG's primary mission is to collect community input, foster consensus, and help shape the long-term goals of IR astrophysical science and technology. Our main priority is to reach out to the community spanning the entire IR wavelength range, including users of current facilities like SOFIA, ALMA, and the range of suborbital platforms, as well as upcoming observatories like the

IRSTIG January 2022 AAS Splinter Session

Webb and *Roman* Telescopes. This semi-annual newsletter highlights recent results, technological developments, and events of relevance to the IR community. We encourage your contributions describing interesting, unique, and important science and technology breakthroughs from all our readers. Throughout the year, we continue to host a monthly webinar series (<https://cor.gsfc.nasa.gov/sigs/irsig.php>) and an annual splinter session at the winter AAS meeting. We encourage members of the community to get involved with the IR STIG, and remain dedicated to ensuring our activities reflect the needs of our community, stakeholders, and early-career scientists of diverse backgrounds.

Sincerely,
IR STIG Leadership Council

IRSTIG Splinter Session: proceedings

As every year, the IRSTIG put together a special session at the time of Winter AAS. These regular events serve as an opportunity for the community to stay connected and informed about activities in the field. On January 4th, 2022, we were fortunate to host 13 lively flash talks on current projects, spanning topics such as balloon missions, detector technology, future probe designs, and research on current facilities. The event was a success in bringing us together as a community to advocate for IR science and technology.

You can find the presentation at our IRSTIG website:

https://cor.gsfc.nasa.gov/sigs/irsig/events/meetings/Winter_Jan2022/Winter_Jan2022.php

IRSTIG WORKSHOP MAR 30-APR 1



Astro2020 and IR Astrophysics: Planning for the Next Decade

March 30 – April 1 Boulder, CO

The IRSTIG is excited to present an upcoming workshop addressing Astro2020 and the future of infrared astronomy and technology! The goal of this workshop will be to give the IR science and technology community an opportunity to synthesize the priorities and recommendations of the Astro2020 Decadal Survey, and to provide a forum for thoughtful discussion and deliberation about the future of our field in the next decade and beyond. We will use this platform to bring diverse voices into the room and begin planning for potential new missions. Sessions will include a mix of structured and unstructured time to allow participants to talk in small groups and collaborate.

Potential Topics for Discussion:

Precursor Science - What Science Do We Need to Do Now?

Future Science - What are the Science Cases for Future Missions?

Technology Development for the Future

Probes and Flaglets for the FIR

The Role of Sub-Orbital in Technology and Science

The Future of SOFIA

Putting the 'IR' in LUVOIR

Creating a Coherent Vision Over Three Decades in Wavelength

Pre-registration will be closing January 24, 2022. Stay tuned for the opening of full registration and abstract submission! We are planning to have registration for the workshop be free to all attendees. We will continue to send all email announcements to the [IRSTIG](#) mailing list. Please sign-up to stay in the loop about this workshop and all other IRSTIG activities!

<https://casa.colorado.edu/~mema5817/irworkshop.html>

Astro2020 report paints the IR landscape for the next decade

Arielle Moullet (SOFIA/USRA)

Last November, the National Academy of Sciences released its long-awaited Decadal report (Astro2020), synthesizing the outcome of years of discussions amongst an impressive lineup of more than 150 committee members and panelists. The report is in part based on input from the community at large through more than 570+ white papers collected in 2019, covering all areas of astrophysics and associated technology research. It puts forth a series of programmatic recommendations aimed at maximizing compelling discoveries over a list of identified priority research areas, together with strategies to support a strong and diverse community of researchers.

While advisory in nature, the report will be a strong guide for US agencies, providing a pathway for a coordinated approach to astronomy development in this decade and part of the next one. For our community of IR astronomers, Astro 2020 paints a very detailed picture of what the near future could look like, in terms of technological development opportunities, supported scientific research priorities, and overall community sustainability.

One of the main outcomes of the proposal is a strong support for a large Infrared/Optical/Ultraviolet space telescope to be developed in the next two decades with a target launch in the first half of the 2040s. This telescope would be the first project developed through a new approach for planning and implementing large missions, the Great Observatories Mission and Technology Maturation Program. The recommended design would include a large



(~6m diameter) mirror accommodating high-contrast imaging and spectroscopy - supporting the main identified science theme 'Worlds and Suns in context'. The near- infrared region covered by this telescope would be of paramount importance for the characterization of exo-planetary atmospheres.

Mid and far-IR observations are recognized as a key component to the 'Cosmic Ecosystem' science theme, focused on the interplay of physical processes which connect structures at different scales - from stars to galaxy clusters. In particular, the priority area of galaxy growth relies on IR observations which can peer into dense and obscured galactic centers.

The main proposed access to that wavelength range would be through a highly sensitive far-IR spectroscopy and/or imaging space-based probe mission, which could be developed in the 2020s for a launch around 2030. The probe mission class, new to the NASA Astrophysics Division, would provide strategic complementarity to the Great Observatories Program, with a relatively fast development timeline and for a mission target cost of \$3–5 B (FY20).

The overall proposed path to mid- and far-IR access in the next decades is neither continuous, direct or short. The report recommends that SOFIA, the only current active observatory offering comprehensive access to the mid- and far-IR to the community, ceases activity in the upcoming year. To start operations in 2030, the far-IR probe will have to have successfully competed against an alternate probe proposal, an X-ray telescope complementing the Athena mission. The phased approach of the Great Observatories Mission and Technology Maturation Program, designed to lower risk and provide flexibility, places the development of a strategic Far-Infrared large space telescope even further into the future.

However, the report identifies some avenues to sustain the community and enable strategic IR research during this timeline. While recognizing inherent risk, funding and community-access challenges, it recommends strengthening the balloon program by increasing the number of flights, achieving higher float altitudes, and exploring methods for supporting new PIs. And it also sets forth the path to a strong, strategic and ambitious technology development program, supporting continued funding for the Strategic Astrophysics Technology Program, expanded to cover technology maturation for the probe mission, as well as increased funding levels for the Detector Development and Supporting Technology components of the Astrophysics Research and Analysis Program.

We will see in the coming months how agencies respond to these recommendations, and how we as a community can organize and seize the new opportunities before us.

Early Science Results from the CO Mapping Array Pathfinder

Kieran Cleary

California Institute of Technology

Paper: COMAP Early Science: I. Overview Cleary et al., submitted to ApJ, <https://arxiv.org/abs/2111.05927>

Understanding the origin and evolution of the first stars and galaxies, from Cosmic Dawn to the present day, is a major challenge for astrophysics and cosmology. Current instruments such as the Atacama Large Millimeter/submillimeter Array (ALMA) and the Hubble Space Telescope (HST) are being focused on these epochs, providing detailed measurements of individual high redshift objects. Ongoing molecular line surveys of small areas of sky (1–10 sq. arcmin) are constraining the properties of the brightest galaxies during the Epoch of Galaxy Assembly. On the other end of the scale, all-sky measurements of the cosmic microwave background (CMB) provide a constraint on the total reionization optical depth.

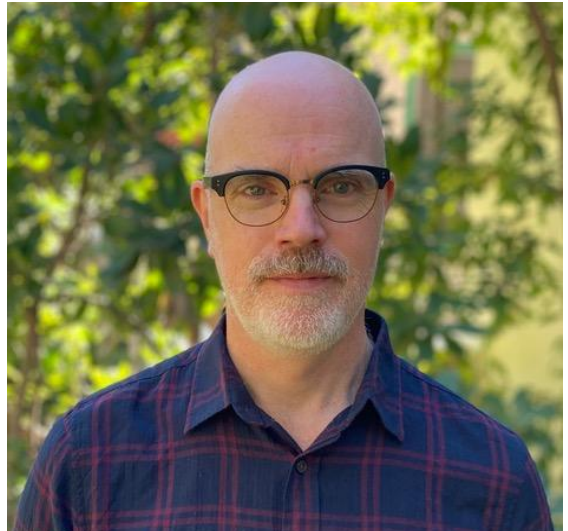

Bridging this huge range in scales, spectral line intensity mapping (LIM) is an emerging technique that has the potential to provide constraints on the faintest galaxies that make up the bulk of the population while surveying large cosmic volumes in a reasonable time. Unlike galaxy surveys, which trace the large-scale distribution of mass by individually detecting large numbers of galaxies, LIM measures the aggregate emission of spectral lines from unresolved galaxies and the inter-galactic medium (IGM). The redshift of the spectral line locates the emission in the line-of-sight direction. This allows efficient mapping of the cosmic luminosity density from a variety of spectral lines over a huge volume of the Universe.

Using CO as the tracer molecule for intensity mapping studies is complementary to other probes and has several advantages. The multiple emission lines of CO, with a well-defined frequency spacing, enable the signal to be separated from contaminating signals. The levels of foreground contamination in a CO survey are substantially lower than for many other types of line intensity

SCIENCE HIGHLIGHTS

mapping, as CO suffers from neither the exceptionally high levels of continuum foregrounds present in 21-cm surveys nor the bright spectral line foreground present in [C II] surveys.

COMAP was funded by the National Science Foundation (NSF) in 2015 to construct a pathfinding instrument (Lamb et al. 2021) for CO LIM. This Pathfinder targets the 26–34 GHz frequency range, which is sensitive to the 115.27 GHz CO(1–0) line in the redshift range $z = 2.4–3.4$ and the 230.54 GHz CO(2–1) line at $z = 6–8$ (see Figure 1, left). The Pathfinder receiver is a single-polarization 19-feed focal plane array, deployed on a 10.4-m Cassegrain telescope at the Owens Valley Radio Observatory (OVRO), resulting in a resolution of 4.5 arcmin at 30 GHz.

The primary goal of the Pathfinder is to detect the power spectrum of CO(1–0) fluctuations from galaxies at $z = 2.4–3.4$ on scales relevant to clustering; that is ≥ 10 Mpc, corresponding to spatial Fourier modes, $k \leq 0.6 \text{ Mpc}^{-1}$. The observed CO power spectrum, $P_{\text{CO}}(k)$, is the sum of clustering and shot-noise terms,

$$P_{\text{CO}}(k) = A_{\text{clust}} P_{\text{m}}(k) + P_{\text{shot}} \quad (1)$$

where A_{clust} is the clustering amplitude, $P_{\text{m}}(k)$ is the dark matter power spectrum, and P_{shot} is the scale-independent shot noise. Mapping in redshift space imposes distortions on the observed intensity field, such that the clustering amplitude is given by $A_{\text{clust}} \approx \langle T_i \rangle^2 (b^2 + 2b/3 + 1/5)$ for small k , where $\langle T_i \rangle$ is the mean CO line intensity and b is the luminosity-weighted bias.

Observations of three $\sim 4\text{-deg}^2$ fields began in 2019 June and continued until 2020 August, when the receiver was removed from the telescope for maintenance. Observing resumed in 2020 November and we refer to the period before receiver maintenance as “Season 1”. Using data from Season 1, we have placed the first direct 3D constraint on the clustering component of the CO(1–0) power spectrum (Ihle et al. 2021; Chung et al. 2021). Based on these observations alone, we obtain a constraint on the amplitude of the clustering component (the squared mean CO line temperature–bias product) of $\langle T_b \rangle^2 < 49 \mu\text{K}^2$ (see Figure 1, right) – nearly an order-of-magnitude improvement on the previous best measurement. These constraints allow us to rule out two models from the literature. We forecast a detection of the power spectrum after 5 years with signal-to-noise ratio (S/N) 9–17. Cross-correlation with an overlapping galaxy survey will yield a detection of the CO–galaxy power spectrum with S/N of 19. We are also conducting a 30 GHz survey of the Galactic plane and present a preliminary map (see Figure 2; Rennie et al. 2021).

The next phase of the project, COMAP-EoR, will involve the addition of a second spectrometer array operating at 12–20 GHz and sensitive to CO(1–0) from redshift $z = 5–9$, deployed on a prototype 18-m next-generation Very Large Array telescope (Breysse et al. 2021).

SCIENCE HIGHLIGHTS

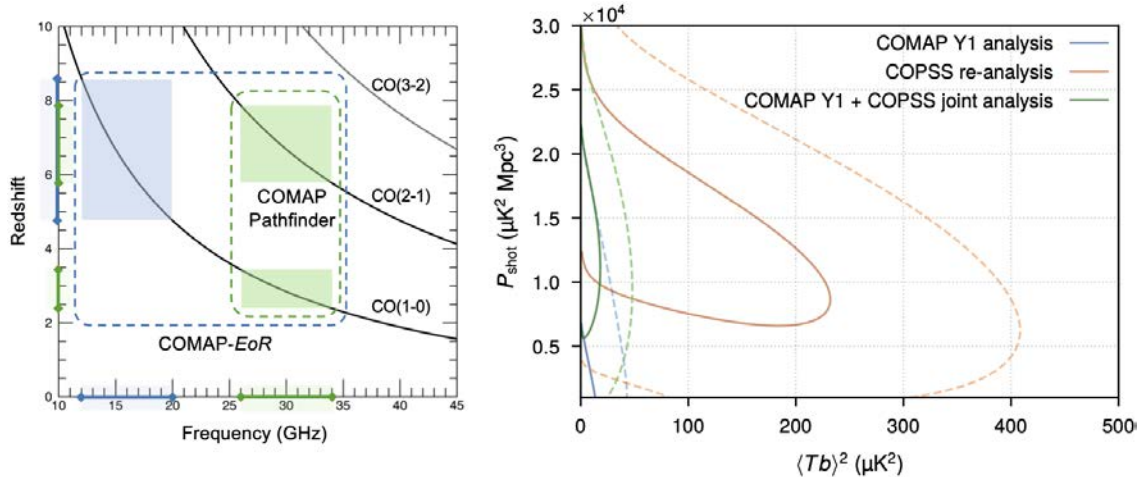

Figure 1 (Left) Redshift of the three lowest CO transition lines as a function of observed frequency. The frequency coverage for the COMAP Pathfinder Survey (26–34 GHz) is sensitive to the CO(1–0) line in the redshift range $z = 2.4$ – 3.4 and the CO(2–1) line at $z = 6$ – 8 . Also shown is the frequency coverage of a future COMAP-EoR survey, in which a second frequency channel (12–20 GHz) is added, sensitive to the CO(1–0) line at $z = 4.8$ – 8.6 . (Right) Likelihood contours for the clustering $\langle(Tb)^2\rangle$ and shot-noise amplitudes of the CO power spectrum, based on different datasets. The contours represent $\Delta\chi^2 = \{1, 4\}$ relative to the minimum χ^2 obtained in the parameter space, representing 1σ (solid) and 2σ (dashed) for 2D Gaussians. With the COMAP Season 1 data alone, we obtain an order of magnitude improvement in the constraint on the clustering amplitude.

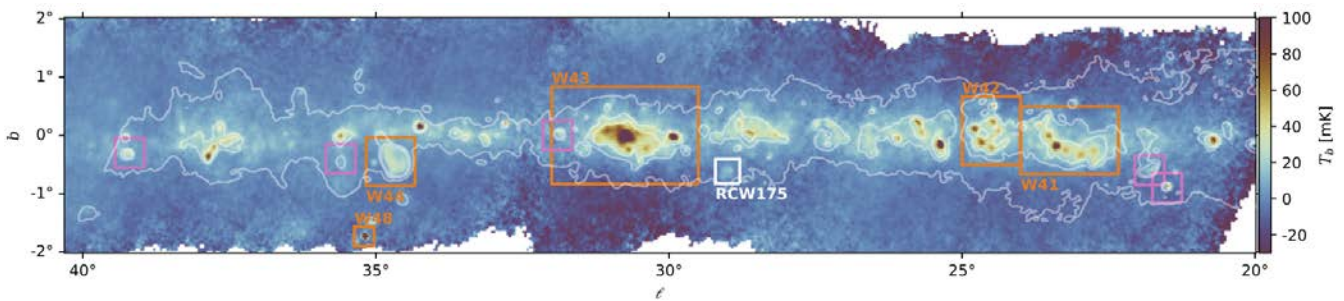

Figure 2. The current COMAP band-averaged 30.5 GHz map covering the Galactic plane between $20^\circ < l < 40^\circ$. The color scale is linear and in units of brightness temperature (mK). Contours are 1.0, 1.5 and 2.0 MJy/sr from the Parkes 5 GHz Galactic plane survey. Well-known Westerhout star-forming complexes are indicated by orange outlines, including the SNR W44. The other detected SNR are indicated by purple outlines. The RCW175 region, for which a spectral decomposition is shown in Figure ??, is indicated with a white outline. Masked pixels are white.

REFERENCES

TECHNOLOGY HIGHLIGHTS

Breysse, P. C., Chung, D. T., Cleary, K. A., et al. 2021, arXiv e-prints, arXiv:2111.05933. <https://arxiv.org/abs/2111.05933> ; Chung, D. T., Breysse, P. C., Cleary, K. A., et al. 2021, arXiv e-prints, arXiv:2111.05931. <https://arxiv.org/abs/2111.05931> ; Cleary, K. A., Borowska, J., Breysse, P. C., et al. 2021, arXiv e-prints, arXiv:2111.05927. <https://arxiv.org/abs/2111.05927> ; Ihle, H. T., Borowska, J., Cleary, K. A., et al. 2021, arXiv e-prints, arXiv:2111.05930. <https://arxiv.org/abs/2111.05930> ; Keating, G. K., Marrone, D. P., Bower, G. C., et al. 2016, ApJ, 830, 34, doi: 10.3847/0004-637X/830/1/34 ; Lamb, J. W., Cleary, K. A., Woody, D. P., et al. 2021, arXiv e-prints, arXiv:2111.05928. <https://arxiv.org/abs/2111.05928> ; Rennie, T. J., Harper, S. E., Dickinson, C., et al. 2021, arXiv e-prints, arXiv:2111.05932. <https://arxiv.org/abs/2111.05932>

Highly multiplexed readout for TES bolometer arrays

John Groh

NIST Boulder

Transition Edge Sensor (TES) bolometers remain the most commonly used detector for continuum observations in the mm/sub-mm/FIR. Consisting of a voltage-biased superconducting thin film located on a thermally isolated membrane, the TES bolometer acts as a relative power meter whose sensitivity has been shown to be background-limited [1] for all but the most demanding space-based spectroscopic applications. The technology is well-suited to the production of large-format arrays and is the gold-standard for measurements of the cosmic microwave background (CMB) from the ground [2–8], on sub-orbital platforms [9–12], and in proposed space missions [13–15]. There is also a strong history of use in the FIR, with instruments including SCUBA2 [16] and HAWC+ on SOFIA [17]. Moreover, several ultra-sensitive demonstrations exist with applicability to future space-based missions [18, 19].



The scale of TES-based focal planes is practically limited by their superconducting readout. The low impedance of the TES is well-matched to SQUID readout, and large arrays require large multiplexing factors. To meet the detector count needs of upcoming instruments, new approaches to SQUID-based multiplexing of TES bolometers are required, as the most commonly used technologies are limited to multiplexing factors of $<100\times$ [20, 21]. At NIST, we are developing microwave SQUID multiplexed readout (μmux), which can in principle achieve a multiplexing factor of tens of thousands. The combination of TES bolometers and μmux readout is highly relevant for NASA IR missions: the Astro2020 decadal survey recommends a new class of probe

TECHNOLOGY HIGHLIGHTS

missions [22], the first of which may be a FIR probe based on the OST which baselines TES bolometers with μ mux readout [23]. Additionally, the combination of TES bolometers with μ mux readout has been identified as an enhancing technology for the funded GEP probe concept [24].

Microwave SQUID multiplexed readout for TES bolometer arrays is rapidly advancing in technological maturity. Already, multiplexing factors of $64\times$ and $528\times$ have been demonstrated in on-sky observations with MUSTANG-2 on the GBT [25] and in the Keck Array [26]. The state-of-the-art μ mux chips [27] and embedding [28] host 455 channels per GHz of bandwidth, operate from 4–6 GHz, and read out 1820 TES bolometers while enabling close hex-packing of many 150 mm modules across an instrument focal plane (see Fig. 1). Several large ground-based millimeter-wave observatories - the Simons Observatory [6], ALICEPT [29], and the BICEP Array [3] - are actively preparing instrumentation to deploy μ mux TES readout for on-sky observations with 104–105 detectors and multiplexing factors between $910\times$ and $2000\times$. Additionally, per-channel noise levels sufficient for meeting the requirements of the future space missions of GEP [24] and PICO [14] have been demonstrated with existing hardware [28].

Microwave SQUID multiplexed readout is essentially a phase modulation scheme on top of a frequency modulation scheme. A schematic of the multiplexer is shown in Fig. 2. Optical power modifies the resistances $R_i(t)$ of the TESs, which are each inductively coupled to a dissipationless rf SQUID consisting of a superconducting loop interrupted by a single Josephson junction. The inductance of each Josephson junction is a function of the magnetic flux applied through its loop. Each SQUID is in turn inductively coupled to a transmission line resonator with a unique natural resonance frequency defined by its electrical length L_i . As a result, the resonance frequency of each resonator is a direct function of the applied flux to the SQUID loop. Many resonators are capacitively coupled to a single feedline, and a comb of microwave probe signals is amplified by a wide-band cryogenic amplifier, allowing a large number of detectors to be read out simultaneously. To linearize the SQUIDs and avoid the need for individual feedback on each channel, an additional “flux-ramp” modulation is applied via a separate inductive coupling to each SQUID [30], encoding the TES signal in the phase of the flux-ramp response. Though the chain of transduction is nontrivial (optical power \rightarrow TES current \rightarrow magnetic flux through the SQUID load inductance of the resonator \rightarrow resonator resonance frequency \rightarrow phase of flux-ramp response), due to scalability of \sim GHz superconducting resonators with quality factors of $\sim 10^5$ and the large amount of bandwidth available at microwave frequencies with modern room temperature electronics, many thousands of channels may in principle be read out within a single microwave line. Fig. 3 shows a demonstration of 905 channels measured simultaneously within 2.25 GHz of bandwidth.

To further improve the capabilities and scalability of microwave SQUID multiplexer technology, we are pursuing several R&D avenues at NIST. Current designs incorporate resonators between 4 and 6 GHz, but a full octave of bandwidth is possible before intermodulation products from amplifier nonlinearities pose a serious obstacle [31]; we therefore are working to extend the

TECHNOLOGY HIGHLIGHTS

usable band up to 8 GHz to double the multiplexer capacity. We are also pursuing a lower frequency implementation, with resonators in the 2–4 GHz range, where microwave engineering difficulties are reduced. At these low frequencies, direct RF tone synthesis and demodulation is possible, potentially reducing the cost and complexity of the room temperature electronics. Separately, a post-fabrication resonator editing procedure developed for MKIDs [32] may enable closer resonator spacing and larger multiplexing factors. Finally, we are exploring a hybrid multiplexing scheme in which multiple SQUIDs are coupled to each resonator, further increasing the channel density. Separately or in combination, these research efforts promise to make TES bolometer arrays an even more attractive option to future IR instruments requiring large numbers of background-limited sensors.

References

- [1] D. Farrah et al., *J. of Astron. Telesc. Instrum. Syst.*, 5(2), 020901 (2019). [2] A. Anderson et al., *J. Low Temp. Phys.* 193, 1057–1065 (2018). [3] H. Hui et al., *Proc. SPIE* 10708, 1070807 (2018). [4] T. Essinger-Hileman et al., *Proc. SPIE* 9153, 91531I (2014). [5] S. W. Henderson et al., *J. Low Temp. Phys.* 184, 771–779 (2016). [6] P. A. R. Ade et al., *J. Cosmol. Astropart. Phys.* 2019(02), 56 (2019). [7] N. Stebor et al., *Proc. SPIE* 9914, 99141H (2016). [8] J.-Ch. Hamilton et al., *J. Cosmol. Astropart. Phys.* (accepted). arXiv:2011.02213. [9] R. Gualtieri et al., *J. Low Temp. Phys.* 193, 1112–1121 (2018). [10] N. N. Gandilo et al., *Proc. SPIE* 9914, 99141J (2016). [11] The LSPE collaboration et al., *J. Cosmol. Astropart. Phys.* 2021(08), 008 (2021). [12] The EBEX Collaboration et al., *Astrophys. J., Suppl. Ser.* 239, 7 (2018). [13] M. Hazumi et al., *Proc. SPIE* 11443, 114432F (2020). [14] S. Hannay et al., *Bull. Am. Astron. Soc.* 51(7), 194 (2019). [15] A. Challinor et al., *J. Cosmol. Astropart. Phys.* 2018(04), 018 (2018). [16] W. S. Holland et al., *M. Notices Royal Astron. Soc.* 430(4), 2513–2533 (2013). [17] D. A. Harper et al., *J. Astron. Instrum.* 07(04), 1840008 (2018). [18] T. Suzuki et al., *J. Low Temp. Phys.* 184, 52–59 (2016). [19] A. D. Beyer et al., *J. Low Temp. Phys.* 167, 182–187 (2012). [20] A. N. Bender et al., *J. Low Temp. Phys.* 199, 182–191 (2020). [21] S. W. Henderson et al., *Proc. SPIE* 9914, 99141G (2016). [22] National Academies of Sciences, Engineering, and Medicine. *Pathways to Discovery in Astronomy and Astrophysics for the 2020s* (2021). [23] C. Battersby et al., *Nat. Astron.* 2(8), 596–599 (2018). [24] J. Glenn et al., *J. Astron. Telesc. Instrum. Syst.* 7(3), 034004 (2021). [25] S. M. Stanchfield et al., *J. Low Temp. Phys.* 184, 460–465 (2016). [26] A. Cukierman et al., *J. Low Temp. Phys.* 199, 858–866 (2020). [27] B. Dober et al., *Appl. Phys. Lett.* 118, 062601 (2021). [28] H. McCarrick et al., *ApJ* 922, 38 (2021). [29] M. Salatino et al., *IEEE Trans. Appl. Supercond.* 31, 5 (2021). [30] J. A. B. Mates et al., *J. Low Temp. Phys.* 167, 707–712 (2012). [31] J. A. B. Mates et al., *Appl. Phys. Lett.* 115, 202601 (2019). [32] X. Liu et al., *Appl. Phys. Lett.* 111, 252601 (2017).

TECHNOLOGY HIGHLIGHTS

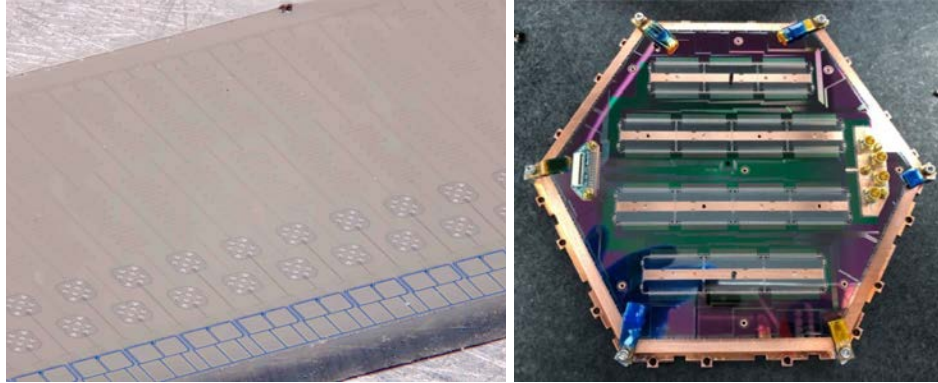

Figure 1: Left: Example μ mux chip containing SQUIDs and resonators fabricated at NIST. Right: Cryogenic assembly of 28 chips demonstrated in [28], capable of reading out 1820 TES bolometers with 2 pairs of coaxial cables and two twisted wire pairs

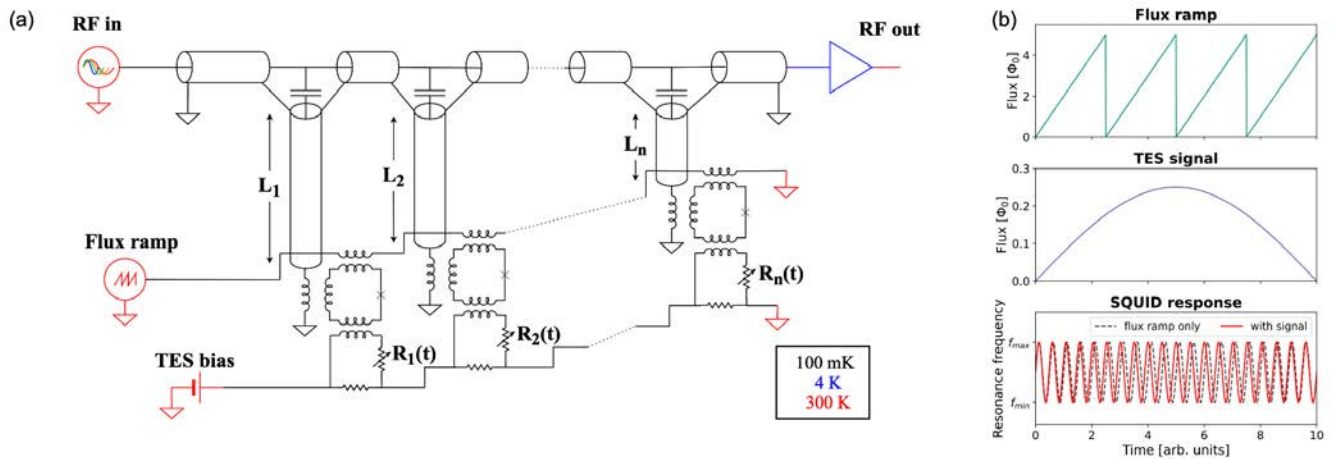

Figure 2: (a) A simplified schematic of the microwave SQUID multiplexer, color-coded by component temperature. (b) Toy model illustrating flux-ramp modulation.

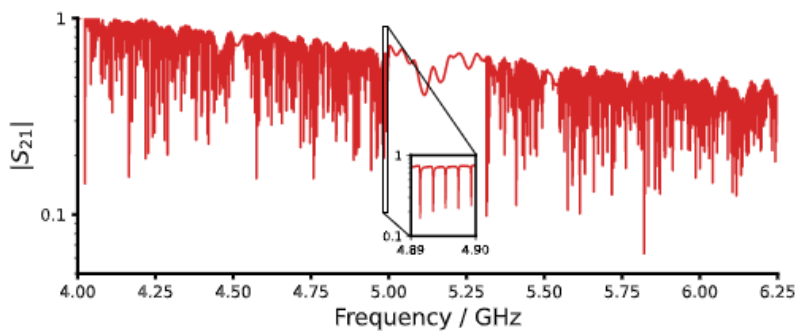

Figure 3: Example measurement of 905 μ mux channels on a single microwave line

COMMUNITY LETTER TO PAUL HERTZ REGARDING SOFIA

Dr. Paul Hertz
Astrophysics Director
Science Mission Directorate
National Aeronautics and Space Administration

December 5, 2021

Dear Paul,

The undersigned are senior users of Stratospheric Observatory For Infrared Astronomy (SOFIA) and we are writing this letter to express our concern on the recommendation in the 2020 Decadal report referring to termination of SOFIA in 2023. There is a well-defined process in place for the evaluation of NASA missions, which is based upon the Senior Review process. The SOFIA Senior Review process is well on its way and we urge to you to let this procedure continue to its completion later in 2022. The Senior Review provides a proper forum for the SOFIA program to present its plans for SOFIA's future and this presentation should include an updated response to previous evaluations such as the Flagship Mission Review, should place SOFIA within the context of the 2020 Decadal Survey, and should specifically address the recent concerns expressed in the Decadal report.

As senior users of SOFIA, it is not surprising that we are highly supportive of SOFIA. In our experience, SOFIA provides a unique platform for cutting edge research centered on far-infrared observations of the universe. About half of the light in the Universe is within the far-infrared range. Conversely, studies in the far-infrared provide new insights in the workings of the Universe as many crucial processes leave their fingerprints in this wavelength range. SOFIA is the only observatory that can probe this important wavelength range for the next decade. SOFIA is also highly complementary to the James Webb Space Telescope both in the respective wavelength ranges that these two missions cover as well as in providing high spectral resolution that provide key kinematic insight. SOFIA also complements well the Atacama Large Millimeter/submillimeter Array, which studies the same processes but then in the far universe where the high redshift has shifted the emission to (sub)-millimeter wavelengths. We consider that SOFIA with its wide array of science instrumentation can address a broad range of science questions within astrophysics. Indeed, SOFIA's science contributions range from water on the moon and in comets within the solar system, to the role of magnetic fields in regulating star formation, to the chemistry of the interstellar medium, in particular in regions of star formation, to feedback by massive stars on the interstellar medium, and to the ecology of galaxies on large scales. As a mission that lands every morning, SOFIA provides also a testbed for new instrumentation. Finally, as SOFIA provides the

COMMUNITY LETTER TO PAUL HERTZ REGARDING SOFIA

only “eyes” in the far infrared sky, SOFIA is of great importance to keep a vibrant far-infrared community alive.

For these reasons, we urge you to allow the SOFIA Senior Review process to continue its evaluation of the SOFIA program.

The affiliations shown below for the undersigned are given for identification purposes only; the opinions expressed by the signatories are their own and do not necessarily represent the views of the institutions with which they are affiliated.

Sincerely yours,

Meredith MacGregor

Robert D. Gehrz, Minnesota Institute for Astrophysics, University of Minnesota

Asantha Cooray, Department of Physics & Astronomy, University of California Irvine

Uma Gorti (SETI Institute/NASA Ames)

Adwin Boogert

Ryan C. Fortenberry, Department of Chemistry & Biochemistry, University of Mississippi

Daniel Dale, Department of Physics & Astronomy, University of Wyoming

William T. Reach, Universities Space Research Association

Paul Goldsmith

Amit Vishwas

Michael Werner

Jens Kauffmann, Haystack Observatory, Massachusetts Institute of Technology

Mark Morris, Department of Physics and Astronomy, UCLA Martin Giard

Emmanuel Caux

Dominique Bockelée-Morvan LESIA, Observatory of Paris

Fabrice Herpin, Laboratoire d'Astrophysique de Bordeaux, France

Luigi Spinoglio IAPS-INAF, Roma, Italy

Jordan Wheeler

David Chuss, Department of Physics, Villanova University

Kathleen Kraemer, Institute for Scientific Research, Boston College

Daniel F. Lester

Judy Pipher, University of Rochester

Bernhard Schulz, DSI/Univ. of Stuttgart, Germany Cody

Lamarche Kate Su, University of Arizona

Jorge L. Pineda, Jet Propulsion Laboratory, California Institute of Technology

COMMUNITY LETTER TO PAUL HERTZ REGARDING SOFIA

Karl Gordon (Space Telescope Science Institute)
Maryvonne Gerin, Observatoire de Paris, France
Howard A. Smith
Omid Noroozian, Detector Systems Branch, NASA GSFC
Jin Koda
Kimberly Ennico, NASA Ames Research Center
Sarah Nickerson
Itsuki Sakon
Margaret Meixner
S. Thomas Megeath, Dept. of Physics and Astronomy, U. of Toledo
Tony Wong, University of Illinois
Andrew Harris
William J Fischer, Space Telescope Science Institute
Peter Barnes, Space Science Institute
Gabriel A. P. Franco
Crystal Brogan
Hendrik Linz, MPIA Heidelberg, Germany
Imke de Pater, UC Berkeley
Ming Sun
Robert Gutermuth, Department of Astronomy, University of Massachusetts Amherst
Giles Novak, Dept. of Physics and Astronomy, Northwestern University
Els Peeters, Department of Physics and Astronomy, University of Western Ontario
Wanggi Lim
Jan Cami, Department of Physics & Astronomy, University of Western Ontario
Tommy Gert Wiklind melvyn@berkeley.edu
Ngoc Le Tram
Todd Hunter, North American ALMA Science Center, National Radio Astronomy Observatory
Francisca Kemper, European Southern Observatory & Academia Sinica, Taiwan
Alec Hirschauer
Ka Tat Wong, IRAM
Flavia Dell'Agli INAF-Observatory of Rome
Harriet Dinerstein, University of Texas at Austin
Ashkbiz Danehkar
Michelle Creech-Eakman, Department of Physics, New Mexico Institute of Mining and Technology
Dana Baylis-Aguirre, Physics Department, New Mexico Tech
Thushara Pillai
Sara Beck School of Physics and Astronomy Tel Aviv University
Remy Indebetouw, U. Virginia and NRAO

Ravi Sankrit
Nicola Schneider, I. Physik. Institut, University of Cologne
Robert Minchin. USRA
Lars Bonne
Sareh Eftekharzadeh
Randolf Klein
Laura Lenkic
Elizabeth Tarantino, Astronomy Department, University of Maryland
Zeeve Rogoszinski
Agnes Kospal, Konkoly Observatory, Hungary
Aaron Bryant Locke Spencer, Department of Physics and Astronomy, University of Lethbridge
Péter Ábrahám, Konkoly Observatory, Budapest, Hungary
Arshia M Jacob, Department of Physics and Astronomy, Johns Hopkins University
Juan Antonio Fernández Ontiveros (CEFCA, Spain)
Javier R. Goicoechea, CSIC, Spain.
Marc Audard (University of Geneva)
Reid Contente
Sarah Nickerson
Volker Ossenkopf-Okada
Olivia Jones, UK Astronomy Technology Centre
Dr. Frédéric Galliano, Département d'Astrophysique, CEA Paris-Saclay, France
Martin Cordiner
Miguel Sanchez Portal
Andrey M. Sobolev, Astronomical Observatory, Ural Federal University, Russia
Howard Smith
Dominik Bomans
Matt Griffin, Cardiff University, UK
Carsten Kramer ,Institut de Radioastronomie Millimétrique
Bernhard Schulz, DSI University of Stuttgart
Thijs de Graauw, ESO emeritus Director of ALMA, Chile
Philippe André, CEA Paris-Saclay
Michael Zemcov (RIT)
Hendrik Linz (MPIA Heidelberg, Germany)

CC: Dr. Thomas Zurbuchen, Associate Administrator, NASA Science Mission Directorate

UPCOMING EVENTS

19-21 Jan 2022 The next generation mid/far-IR space missions – formulating a European perspective – Online

<https://spaceir.sciencesconf.org/>

2-4 Feb 2022 SOFIA School 2022 – Online

<https://sofia-school-2022.constantcontactsites.com/>

8-10 Feb 2022 Exploring the Transient Universe with the Nancy Grace Roman Space Telescope – Caltech and Online

<https://www.ipac.caltech.edu/event/2022-roman-exploring-the-transient-universe>

14-18 Feb 2022 IR2022: An Infrared Bright Future for Ground-based IR Observatories in the Era of JWST – Online

<https://www.ir.isas.jaxa.jp/IR2022/index.html>

28 Feb- 4 Mar 2022 Our Galactic Ecosystem: Opportunities and Diagnostics in the Infrared and Beyond - Lake Arrowhead, CA

<https://arrowhead-2022.constantcontactsites.com>

21-23 Mar 2022 Far-IR Probe Science Workshop - Pasadena, CA

<https://www.ipac.caltech.edu/event/farirprobe>

30 Mar -01 Apr 2022 Astro2020 and IR Astrophysics: Planning for the Next Decade - Boulder, CO

<https://casa.colorado.edu/~mema5817/irworkshop.html>

19 - 21 Apr 2022 Inflatable architectures for the next generation of space telescopes - Tucson, AZ

For information and registration, contact Chris Walker (cwalker@arizona.edu) or Jon Arenberg (jon.arenberg@ngc.com)

CONTACT US

Keep in touch with the IR Science and Technology Integration Group.

IR STIG WEBSITE

<https://cor.gsfc.nasa.gov/sigs/irsig.php>

Our website is hosted on the NASA Cosmic Origins website. It is a continual work in process; please contact us with any questions, comments, or suggestions for content.



@ir_sig

EMAIL LIST

https://cor.gsfc.nasa.gov/sigs/irsig/maillist/irsig_maillist.php

Sign up for announcements, information, and community discussion on our new email listserv! If you have been receiving email from us, no action is necessary, but if you have fallen out of touch or want to subscribe for the first time, please sign up.

IR STIG LEADERSHIP COUNCIL

The current members of the IR Science and Technology Integration Group Leadership Council are:

MeredithMacGregor (Co-Chair)	University of Colorado Boulder
Mike Zemcov (Co-Chair)	Rochester Institute of Technology
Stacey Alberts	University of Arizona
Pete Barry	Argonne National Laboratory
Jake Connors	National Institute for Standards and Technology
Lisa Locke	NASA JPL
Arielle Moullet	SOFIA USRA
Roberta Paladini	Caltech IPAC
Johannes Staguhn	Johns Hopkins University, NASA GSFC
Kevin Stevenson	Applied Physics Laboratory
Volker Tolls	Harvard Center for Astrophysics

Additional information about the IR STIG or to contact the IR STIG LC directly, email: irsiglc@gmail.com.